

SEIT 1928

KONDENSATORMIKROFONE
FÜR STUDIO - UND MESSTECHNIK

MICROTECH GEFELL



M 900 M 910

Studio Condenser Microphones for extraordinary demands with a future oriented design

large diameter pressure gradient transducer

M 900 with cardioid polar pattern

M 910 with hypercardioid polar pattern

The M 900 and M 910 condenser microphones have been developed for recordings of instrumental and vocal soloists in the professional market. Its well balanced frequency response in the free field as well as in the diffuse field and the appropriate distinct characteristics ensure clean and colourless recordings of any sound sources with good selectivity.

It is advisable to use the M 910 by soloists because it shows a specially optimised frequency response for this kind application. A distance of less than 8 to 12 inches, which is recommended as minimum distance between lips and microphone, causes a coloration with an emphasis of lower frequencies, the proximity effect.

An acoustic filter integrated in the protective basket reduces the pop sensitivity. The direction of maximum sensitivity is axial, i.e. endwise to the microphone. This fact and the ergonomic design make these microphone the right choice for live performance of soloists.

Following the modern trend of technique the transducer is equipped with a gold plated polyester membrane.

The newly developed transformerless impedance transducer having a balanced output stage guarantees a high output capability and low intrinsic noise. Together with the good qualities of the microphone capsule a high brilliance of the live performance is reached. A 10 dB attenuator is installed to reduce the sensitivity of the microphone when placed near extremely loud sound sources. And a low frequency roll-off switch will reduce the proximity effect when close miking. The two switches are sunk placed in the middle of the amplifier.

At the lower end of the amplifier the microphone is equipped with a 3-pin XLR connector fitting to the microphone cable C 70. These microphones use 48 volt phantom powering according to the international standards DIN 45596 and ICE 26815.



Delivery

Microphone M 900 in wooden case dark bronze	L x B x H 275 x 90 x 70 mm	Order-No. 211140
--	----------------------------	------------------

Microphone M 910 in wooden case dark bronze	L x B x H 275 x 90 x 70 mm	Order-No. 211141
--	----------------------------	------------------

Accessories, optional

Windscreen, anthrazite	W 90	Order-No. 202403
Popscreen, black	PO 70	Order-No. 600018
Clamp, black	MKV 8	Order-No. 600014
Elastic suspension, dark bronze	EA 90	Order-No. 202314
Elastic suspension, anthracite	only for delivered by MTG AT 8410 a	Order-No. 600004
Table stand, dark bronze	TS 90	Order-No. 212306
Table stand for 2 microphones with Double mount, dark bronze	TS 68 TD 93	Order-No. 202309 Order-No. 202332
Power supply	N 200	Order-No. 202101
Connection cable	C 70	Order-No. 202212

Specifications

CE Certifikate

M 900

M 910

Transformerless Studio Condenser Microphone

Polar patterns		cardioid	hypercardioid
Acoustical operating principle		Pressure gradient transducer	
Frequency range		40 ... 18000 Hz	40 ... 18000 Hz
Sensitivity at 1 kHz		17 mV/Pa	14 mV/Pa
Switch position "reduced bass roll-off" at 90 Hz		-10 dB	-10 dB
Rated impedance		150 Ω	150 Ω
Equivalent loudness level	CCIR 468-4	21 dB	22 dB
due to inherent noise	DIN EN 60 651	13 dB - A	15 dB - A
Signal-to-noise-ratio	CCIR-weighted	73 dB	72 dB
(re. 1 Pa at 1 kHz)	A-weighted	81 dB	79 dB
Max. SPL for THD ≤ 0,5 %		133 dB	135 dB
with 10 dB preattenuation		143 dB	145 dB
Total dynamic range of the microphone amplifier		120 dB	120 dB
Current consumption (P 48, DIN 45596, IEC 268-15)		3 mA	3 mA
Output connector		3-pin XLR connector goldplated contacts	
Weight		229 g	229 g
Dimensions (L x Ø)		218 mm x 47/28 mm	218 mm x 47/28 mm
Finish		dark bronze	dark bronze

Frequency responses M 900

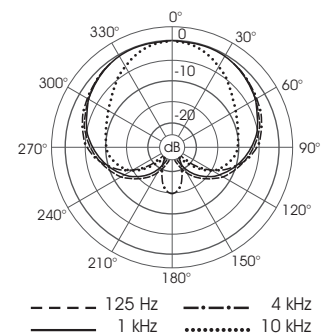
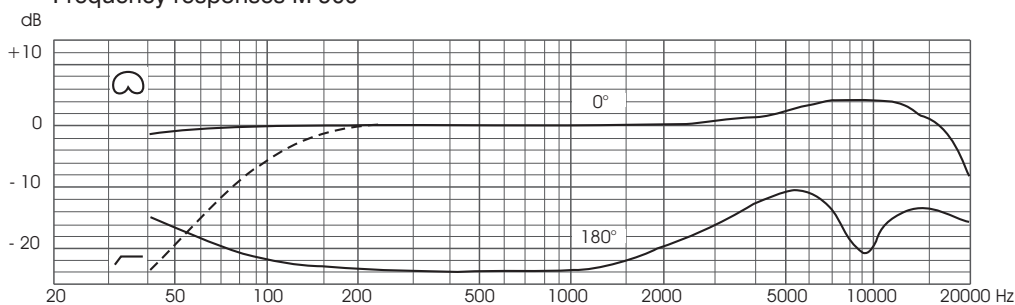

Frequency responses M 910

